

Carolena's Dove In The Window

Overall Size: 73" by 73"
Reproduction pattern based on turn of the century quilt made by
Carolena Winters Newkirk
You can view the original quilt and story on the web at
www.doveinthefwindow.com

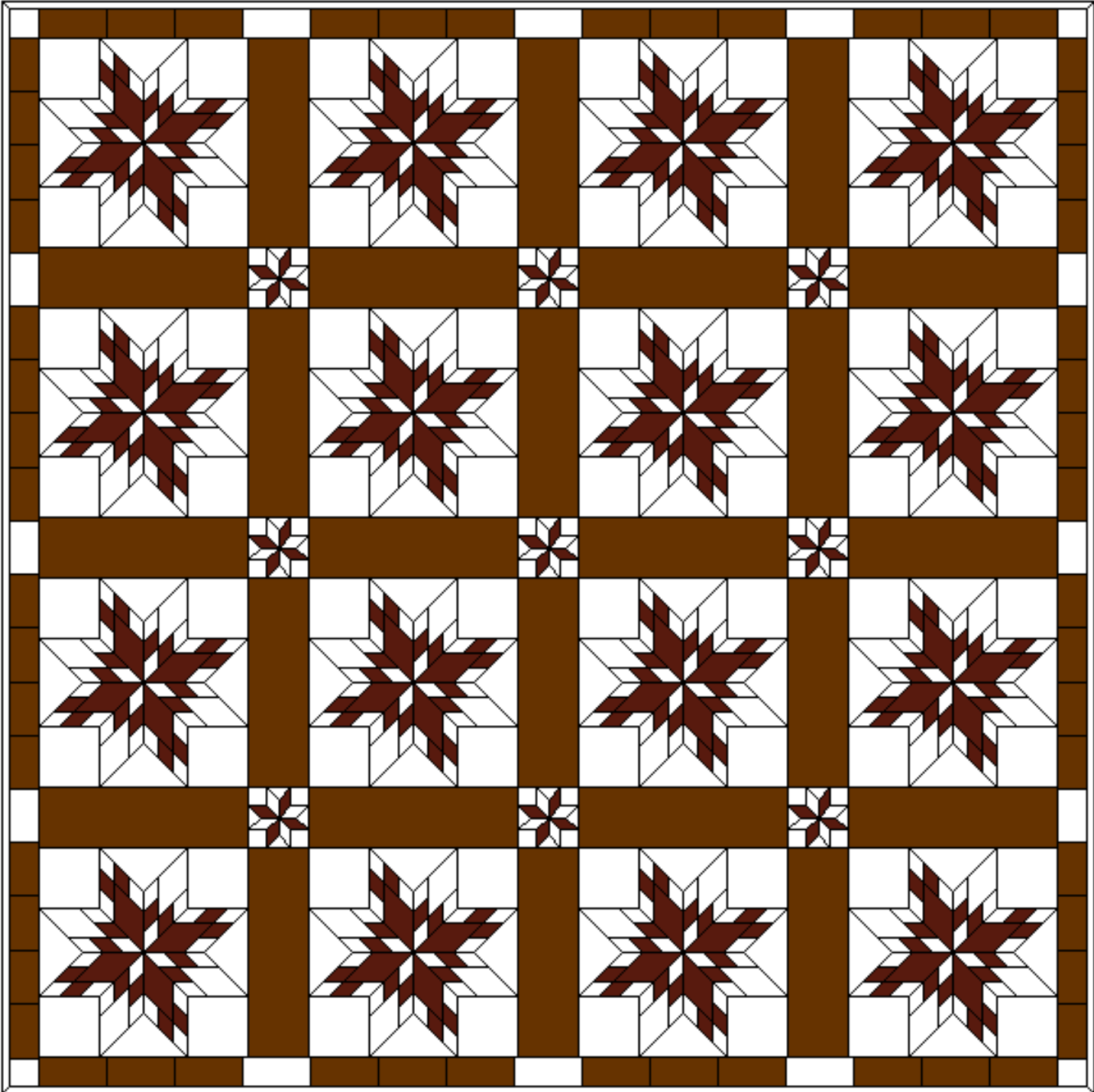

Dove In The Window

Reproduction pattern based on Carolena Winters Newkirk original quilt

Overall Quilt Size approximately 73" wide by 73" long

Fabric Estimates:

40" wide fabric

Quilt Top, borders and binding

- 3 yards Dark Fabric (original quilter used small scale red print)
- 3 yards Light Fabric (original quilter used bleached muslin)

Backing Fabric

- 4.5 yards (original quilter used bleached muslin)

Batting Estimates:

At least 77" wide

- 2.5 yards (original quilter used cotton batting)

Cutting

Borders

- cut 16 dark rectangles – 2.5" wide by 14.5" long
- cut 12 light rectangles – 2.5" wide by 4.5 long
- cut 4 light squares – 2.5" wide by 2.5" long
- Use a contrasting color pencil to mark a sewing line ¼" from the edge of each piece
- Make a dot with the pencil at each intersecting line (all corners)
- store in zip lock bag labeled DITW borders

Sashing

- Cut 24 dark rectangles – 4.5" wide by 14.5" long
- Use a contrasting color pencil to mark a sewing line ¼" from the edge of each piece
- Make a dot with the pencil at each intersecting line (all corners)
- Store in zip lock bag labeled DITW sashing

Binding

- You will need about 320" of binding. The original quilt has bleached muslin binding. There are a variety of ways to make binding. I found a wonderful book several years ago by Mimi Deitrich entitled Happy Endings, Finishing the Edges of Your Quilt. I find this book invaluable and refer to it every time I make binding. Check with your local quilt shop or Amazon.com for a copy.

Templates for pieced blocks

- To create the templates, print page 5-7 of this document on card stock.
- The templates include a ¼" seam allowance. I like to hand piece, so I cut the templates on the solid line. If you prefer machine piecing, cut the templates on the dashed line.

General Marking Instructions (hand piecing)

- Using the templates cut on the solid line, mark your fabric on the wrong side using a #2 pencil for the light fabric and a white marking pencil for the dark fabric. Start by marking a dot at each point of the template and then draw dot to dot to create the sewing line.

Dove In The Window

Reproduction pattern based on Carolena Winters Newkirk original quilt

- Mark a quarter inch line around each sewing line. This is the cutting line. The cutting line does not need to be precise for hand piecing. You will be using the dots and sewing line as guides for stitching the pieces together.

4" star blocks

- Cut 36 light fabrics using template A
- Cut 36 light fabrics using template B
- Cut 36 light fabrics using template C
- Cut 36 dark fabrics using template C
- Store in zip lock bag labeled 4" Star Blocks

14" Dove Block blocks

- Cut 64 dark fabrics using template D
- Cut 64 light fabrics using template E
- Cut 64 light fabrics using template G
- Cut 64 light fabrics using template H
- Cut 256 dark fabrics using template F
- Cut 384 light fabrics using template F
- Store in zip lock bag labeled DITW blocks

Assembly

4" star blocks – you will need 9 completed blocks

- Use pieces from zip lock bag labeled 4" star blocks
- Assemble the pieces based on the diagram on page 1 & 5 and the following general instructions
- Form half of the star by joining four C pieces (alternate light and dark) right sides together. Match at the dots and pin, and then sew on the sewing lines. This ensures sharp points in your finished block. Use a single thread and knot at the beginning of each piece. Take three small running stitches - - - and then take a back stitch. End each line with a tiny knot.
- Repeat the previous step to form the other half of the star
- Join the 2 star halves
- Complete the block by adding pieces A and B per diagram. These require inset seams. I find it works best for me to sew from the inset corner out.
- The assembled block should measure 4.5" square.

14" Dove Blocks – you will need 16 completed blocks

- Use pieces from zip lock bag labeled 14" DITW blocks
- This block is also an 8 pointed star like the 4" star block. The only thing is you have to assemble the 8 diamonds that make up the star.
- Assemble the diamonds based on the diagram on pages 1 & 6 using piece D, E & F
- Assemble the star for each block based on the diagram on page 1 using the diamonds you assembled in the previous step. Follow the same process used to assemble the 4" star block
- Complete the Dove block based on the diagram on page 1 using pieces G & H
- The assembled block should measure 14.5" square.

Assemble the Dove rows

- Each row consists of four Dove blocks and three 4.5" by 14.5" sashing rectangles
- Using your Dove blocks and pieces from zip lock bag labeled DITW sashing

Dove In The Window

Reproduction pattern based on Carolena Winters Newkirk original quilt

- Assemble four rows per quilt diagram on page 1
Dove block + sashing + Dove block + sashing + Dove block + sashing + Dove block

Assemble the Star rows

- Each row consists of three 4" star blocks and four 4.5" by 14" sashing rectangles
- Using your 4" star blocks and pieces from zip lock bag labeled DITW sashing
- Assemble three rows per quilt diagram on page 1
sashing + star block + sashing + star block + sashing + star block + sashing

Join the Rows

- Join the Dove rows and star rows per the quilt diagram on page 1
- Use the dots from the template markings on the corner pieces to match and pin. You will be very happy with how your corner points meet and the block alignment.

Assemble the borders

- Use pieces from zip lock bag labeled DITW border
- Assemble the top and bottom borders by joining short edge of four dark rectangles alternately with short edge of three light rectangles - dark + light + dark + light + dark + light + dark
- Assemble the side borders by repeating the previous step and adding a light square to each end
square + dark + light + dark + light + dark + light + dark + square

Add the Borders to the Quilt Top

- Sew the top border to one edge of the quilt top, using dots to match and pin
- Sew the bottom border to the opposite edge of the quilt top
- Sew one of the remaining borders to one side of the quilt top
- Sew the remaining border to the opposite side of the quilt top

Assemble the quilt layers – (top, batting, backing) and baste together all layers

Mark and quilt

- Use whatever design suits you. The original quilt had a variety of quilting patterns. Each piece (1096 by my count) is outlined with tiny (10 per inch) quilting stitches. Each of the large diamond pieces in the Dove block has a simple feather motif. Each corner square and triangle has a flower motif, each sashing rectangle has a long feather motif and the border has a dividing center line crossed with diagonal lines to create a diamond motif.

Complete the quilt by attaching the binding,

Curl up in your new quilt and enjoy :)

Small eight point, diamond, star

Pattern for 4.00x4.00 block

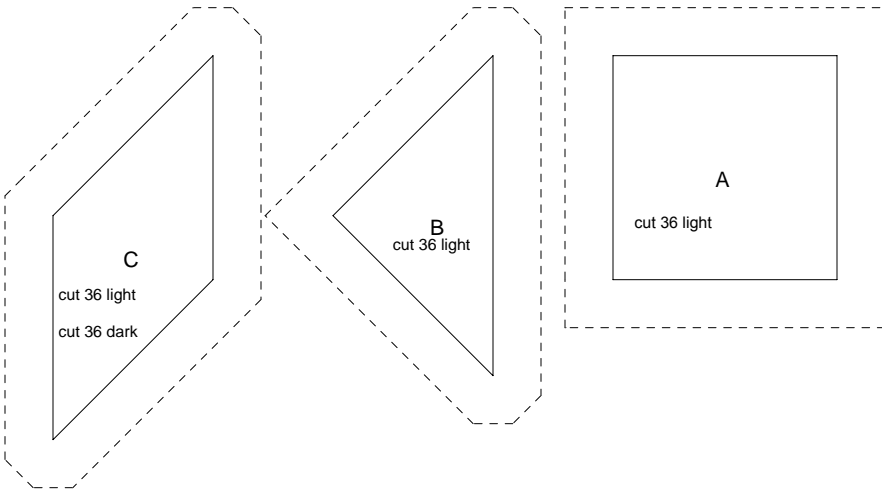
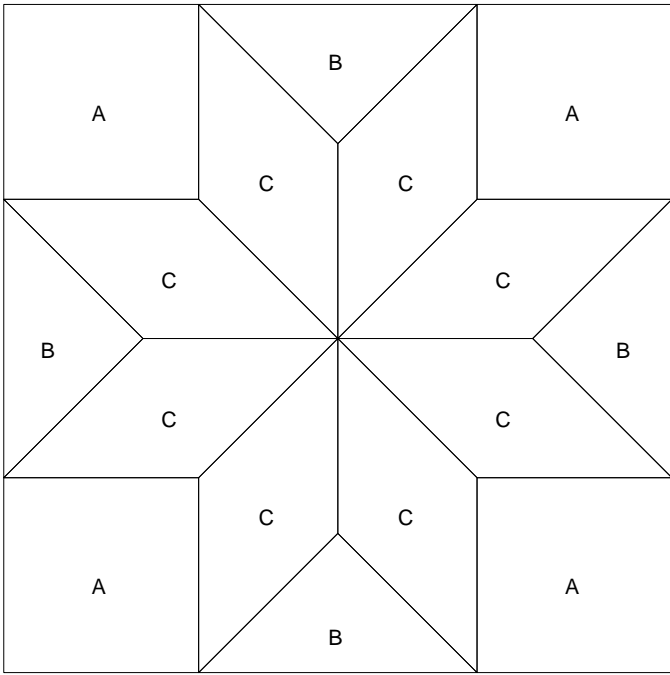

Dove In The Window
Pattern for 14.00x14.00 block

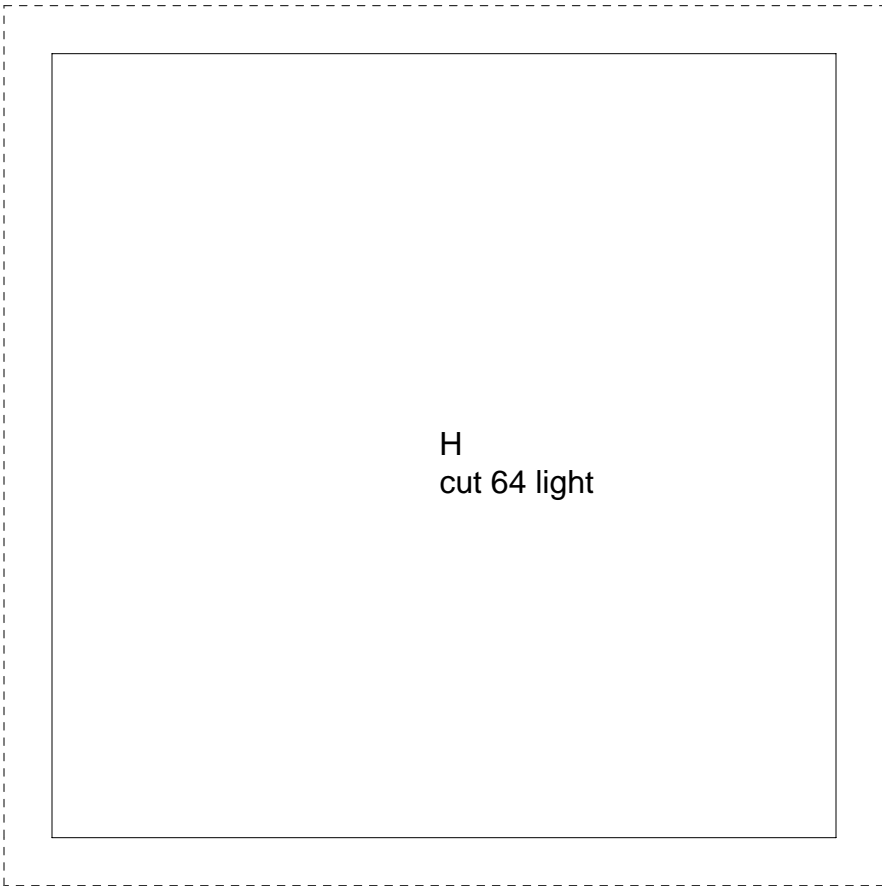
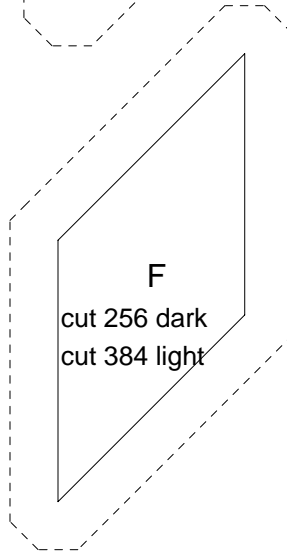
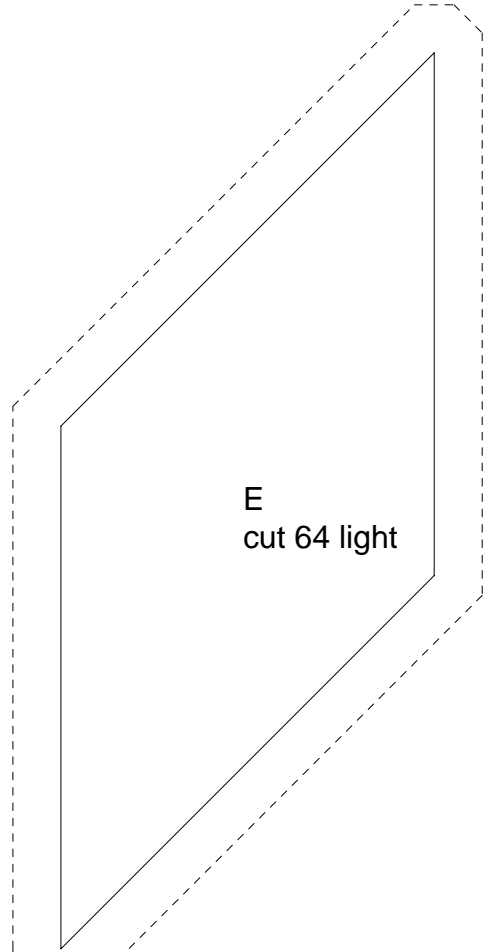
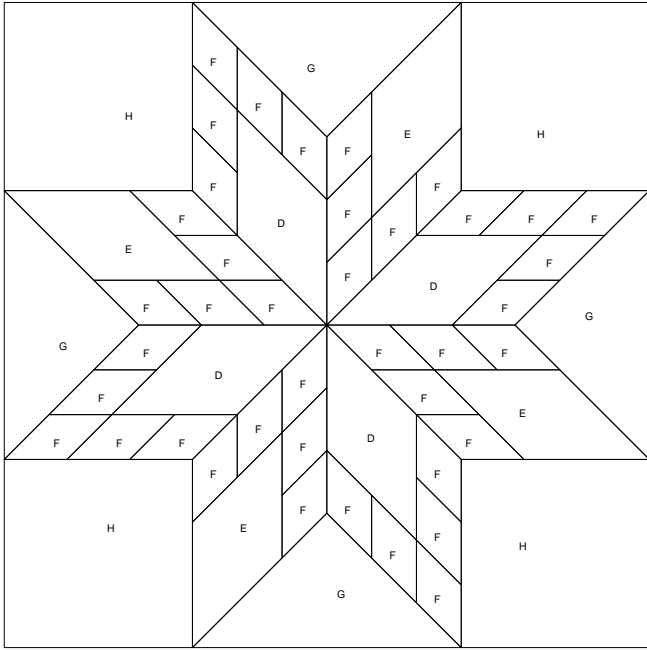

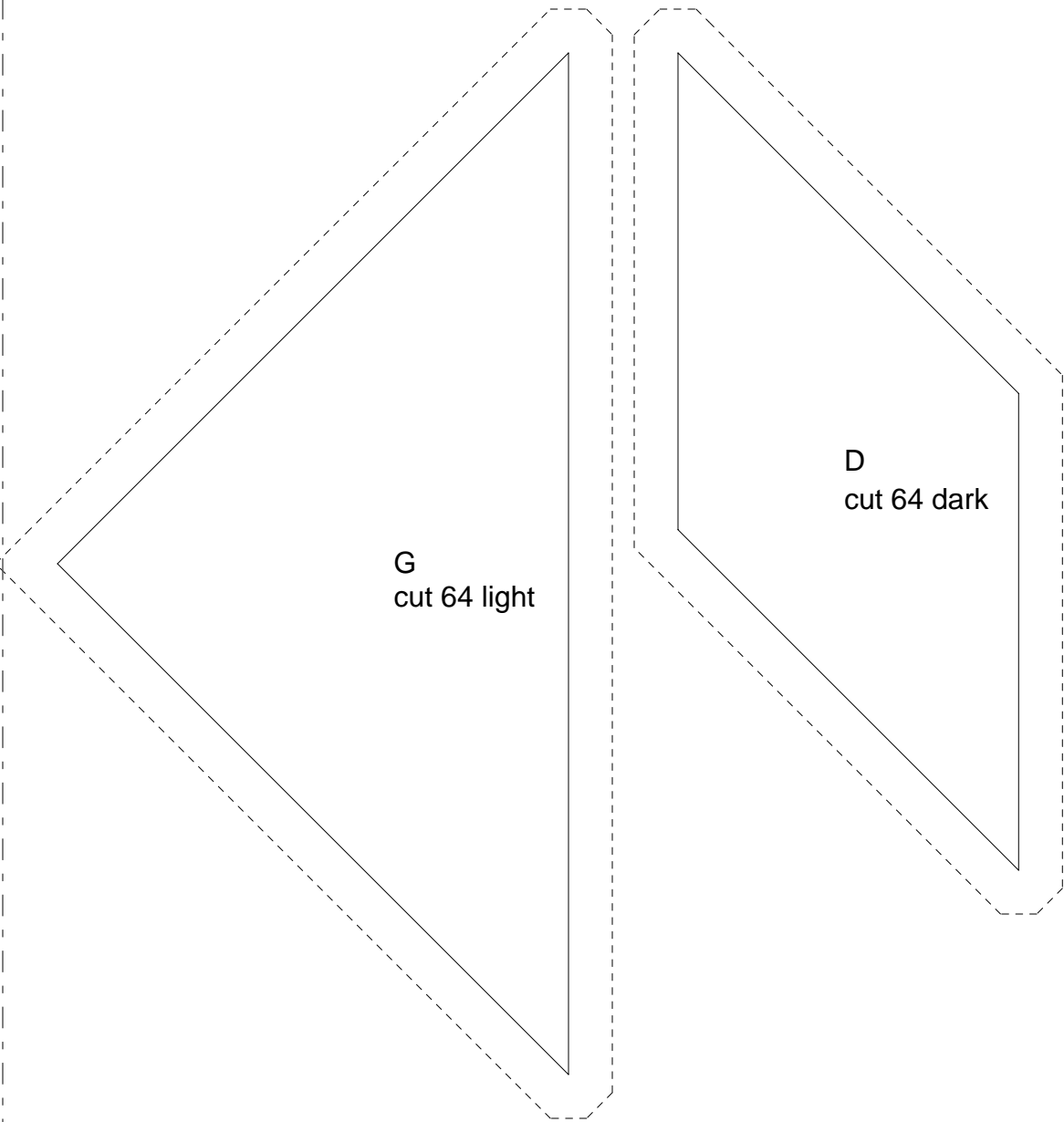

G
cut 64 light

D
cut 64 dark